

SCOTSMAN

WATER FILTRATION SYSTEMS AND REPLACEMENT CARTRIDGES



CLEANER, MORE CONSISTENT ICE CUBES

- Drastically reduces unscheduled, water-related maintenance calls...by as much as 40%.
- Reduces the formation of lime scale, the number one cause of service related problems.
- 99% removal of corrosive chlorine from the incoming water supply.
- Takes out off-tastes and odors.
- Traps dirt and rust particles as small as one-half micron in size, resulting in crystal clear, healthier ice.

WARRANTY PROTECTION *See dealer for complete warranty details.*

- 1 year parts and labor.

NSF INTERNATIONAL STANDARDS

Standard No. 42: Aesthetic Effects

Chemical Unit

Chlorine Reduction, Class 1

Taste and Odor and Reduction

Mechanical Filtration Unit

Particulate Reduction, Class I:

99.9% reduction of particles

1/2 micron and larger in size

Standard No. 53: Health Effects

Mechanical Filtration Unit

Turbidity Reduction

Cyst Reduction

Asbestos Reduction

The SSM filter and replacement cartridge have been Tested and Listed by NSF only for the functions listed above. Check for compliance with state and local laws and regulations. Do not use where the water is microbiologically unsafe, or with water of unknown quality without adequate disinfection before or after the unit. Can be used on water that may contain filterable cysts.

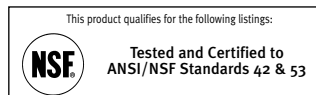

Scotsman[®]
A WELBILT[®] COMPANY

Water Filtration Systems & Replacement Cartridges

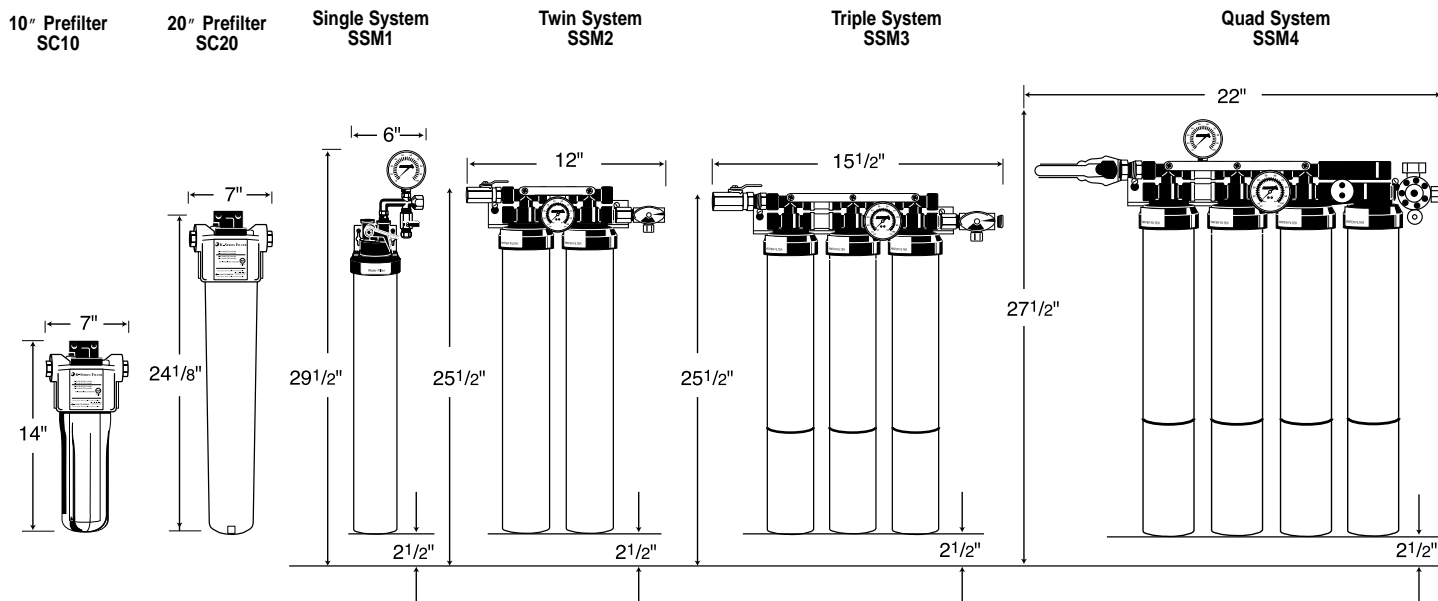

IMPORTANT: Must have minimum 2 1/2" clearance for cartridge change.

Water Filter Systems

Model	Dimensions* W x D x H	Shipping Weight lb./kg.	Used On	Flow Rate gallons per minute
SSM1	69 x 59 x 29 1/2"	7/3	Cubers up to 650 lb., flakers, nuggets, and nugget dispensers up to 1,200 lb.	1.67
SSM2	12" x 5 1/2" x 25 1/2"	11/5	Cubers from 650 to 1300 lbs., flakers and nuggets over 1,200 lb., all 2000 Rapid Freeze by Howe Series flakers	3.34
SSM3	15 1/2" x 5 1/2" x 25 1/2"	16/7	Cubers over 1300 lbs., all 3000/4000 Rapid Freeze by Howe Series flakers	5.01
SSM4	22" x 7" x 27 1/2"	20/9	All 6000 Rapid Freeze by Howe Series flakers	6.68

Coarse Pre-Filters

SC10	7" x 7" x 14"	5/2	109 Coarse prefilter to remove particles	5.00
SC20	7" x 7" x 24 3/8"	11/5	209 Coarse prefilter to remove particles	10.00

*Includes 2 1/2" clearance below.

REPLACEMENT CARTRIDGES

Model	Per Package Quantity	Shipping Weight lb./kg.	Used On
SSMRC1	1	3/1	SSM1 - SSM4
SSMRC6	6	7/3	SSM1 - SSM4
SC10RC40	40	17/8	SC10
SC20RC20	20	17/8	SC20

IMPORTANT OPERATING REQUIREMENTS:

	Minimum	Maximum
Air Temperatures	50°F (10°C)	100°F (37.7°C)
Water Temperatures	40°F (4.4°C)	100°F (37.7°C)
Water Pressures	20 PSIG	120 PSIG
Capacity	Certified for chlorine reduction for up to 9000 gallons	
Flow Rate	1.67gpm (6.3 Lpm) per cartridge	

Scotsman's ice machines are not designed for outdoor installations. Scotsman remote condensers are designed for outdoor installations.

Machine requires voltage indicated on rating name plate. Failures caused by improper voltage are not considered factory defects. Extended periods of operation at temperatures exceeding limitations constitutes misuse under the terms of Scotsman Manufacturer's Limited Warranty, resulting in a loss of warranty coverage. Specifications and design are subject to change without notice.

Consult Your Local SCOTSMAN Representative At:

YOU'LL VALUE THE DIFFERENCE.™

775 Corporate Woods Parkway • Vernon Hills, IL 60061 • 1-800-SCOTSMAN • (847) 913-9844
Visit our website at: www.scotsman-ice.com • E-mail: customer.service@scotsman-ice.com

Scotsman®
A **WELBILT®** COMPANY